

Description

The ASRV05-4 is a low capacitance TVS array, utilizing leading monolithic silicon technology to provide fast response time and low ESD clamping voltage, making this device an ideal solution for protecting voltage sensitive high-speed data lines. The ASRV05-4 complies with the IEC 61000-4-2 (ESD) with $\pm 30\text{kV}$ air and $\pm 30\text{kV}$ contact discharge. It is assembled into a 6-lead SOT23-6 lead-free package. The leads are finished with lead-free matte tin. Each device will protect up to four high-speed lines. The combination of small size, low capacitance, and high surge capability makes them ideal for use in applications such as 10/100 Ethernet, USB 2.0, and visual interfaces.

Features

- Low capacitance: 1.5pF typical (I/O to I/O)
- Ultra low leakage: nA level
- Low operating voltage: 5V
- Low clamping voltage
- Up to 4 lines and one power line protects
- Complies with following standards:
 - IEC 61000-4-2 (ESD) immunity test
Air discharge: $\pm 30\text{kV}$
Contact discharge: $\pm 30\text{kV}$
 - IEC61000-4-5 (Lightning) 20A (8/20 μs)
- RoHS Compliant

Mechanical Characteristics

- Package: SOT23-6
- Lead Finish: Matte Tin
- Case Material: “Green” Molding Compound
- Terminal Connections: See Diagram Below
- Marking Information: See Below

Applications

- USB 2.0 power and data line
- Monitors and flat panel displays
- Set-top box and digital TV
- Video graphics cards
- Digital visual interface (DVI)
- Notebook Computers
- SIM Ports
- 10/100 Ethernet
- IEEE 1394 firewire ports

Marking Information

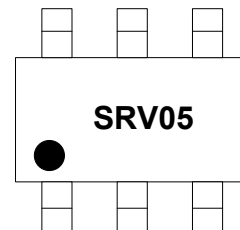

SRV05 = Device Marking Code
Dot denotes Pin1

Ordering Information

Part Number	Packaging	Reel Size
ASRV05-4	3000/Tape & Reel	7 inch

Dimensions and Pin Configuration

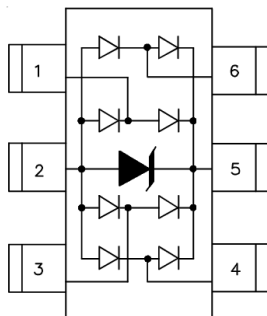

SOT-23 6L (Top View)

Circuit and Pin Schematic

Absolute Maximum Ratings ($T_A=25^{\circ}\text{C}$ unless otherwise specified)

Parameter	Symbol	Value	Unit
Peak Pulse Power (8/20 μs)	Ppk	400	W
Peak Pulse Current (8/20 μs)	I _{PP}	20	A
ESD per IEC 61000-4-2 (Air) ESD per IEC 61000-4-2 (Contact)	V _{ESD}	± 30 ± 30	kV
Operating Temperature Range	T _J	-55 to +125	$^{\circ}\text{C}$
Storage Temperature Range	T _{stg}	-55 to +150	$^{\circ}\text{C}$

Electrical Characteristics ($T_A=25^{\circ}\text{C}$ unless otherwise specified)

Parameter	Symbol	Min	Typ	Max	Unit	Test Condition
Reverse Working Voltage	V _{RWM}			5	V	
Breakdown Voltage	V _{BR}	6			V	I _T = 1mA, Pin 5 to Pin 2
Reverse Leakage Current	I _R			1	μA	V _{RWM} = 5V, Pin 5 to Pin 2
Forward Voltage	V _F			1.2	V	I _F = 15mA
Clamping Voltage	V _C			12	V	I _{PP} = 1A (8 x 20 μs pulse), any I/O pin to ground
Clamping Voltage	V _C			20	V	I _{PP} = 20A (8 x 20 μs pulse), any I/O pin to ground
Junction Capacitance	C _J		1.5		pF	V _R = 0V, f = 1MHz, between I/O pins
Junction Capacitance	C _J		3.0	5.0	pF	V _R = 0V, f = 1MHz, any I/O pin to ground

Note 1: I/O pins are Pin 1, 3, 4 and 6

Typical Performance Characteristics ($T_A=25^\circ\text{C}$ unless otherwise Specified)

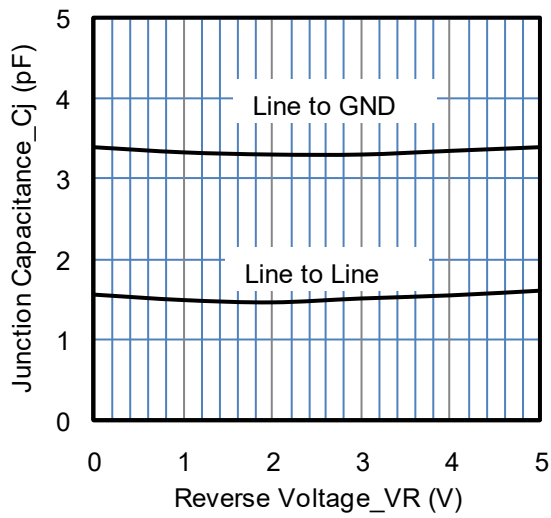

Junction Capacitance vs. Reverse Voltage

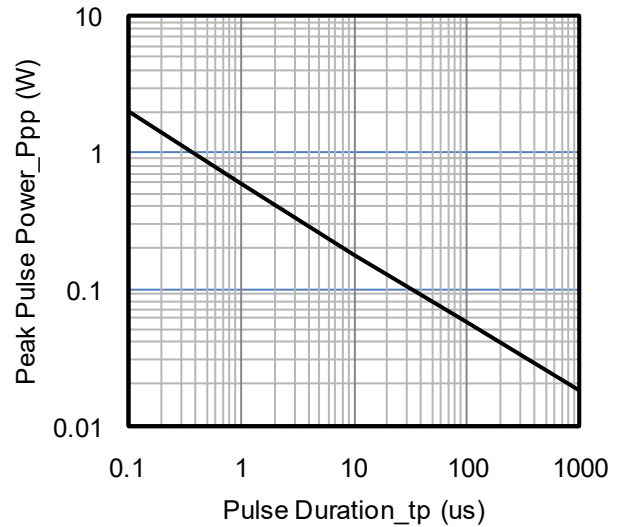

Peak Pulse Power vs. Pulse Time

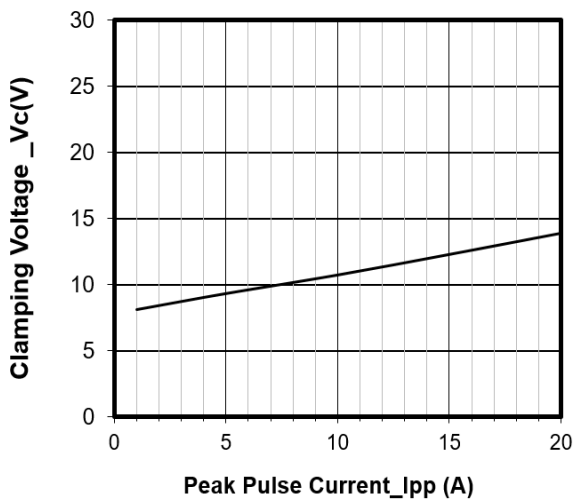

Clamping Voltage vs. Peak Pulse Current

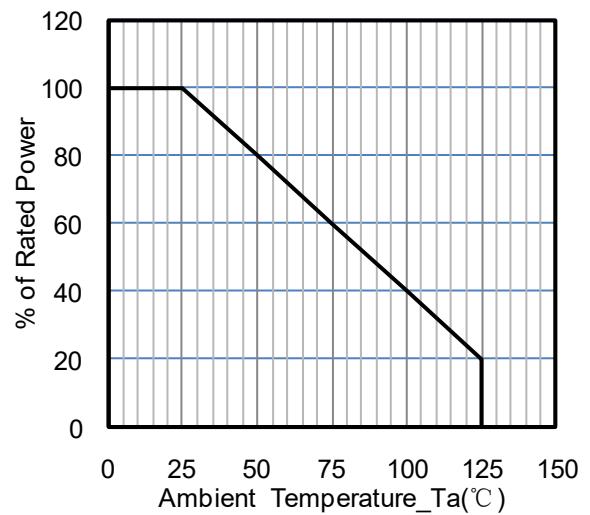

Power Derating Curve

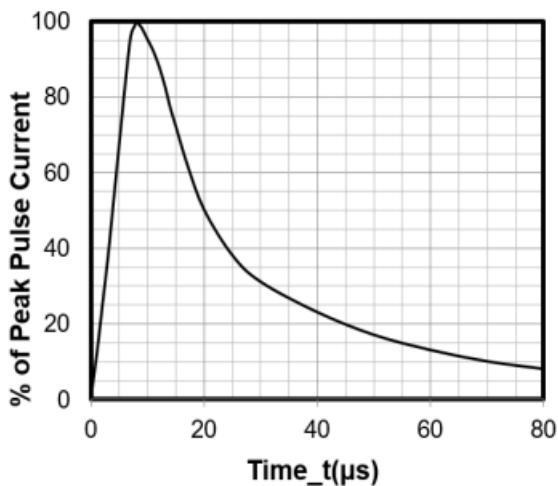

8 X 20µs Pulse Waveform

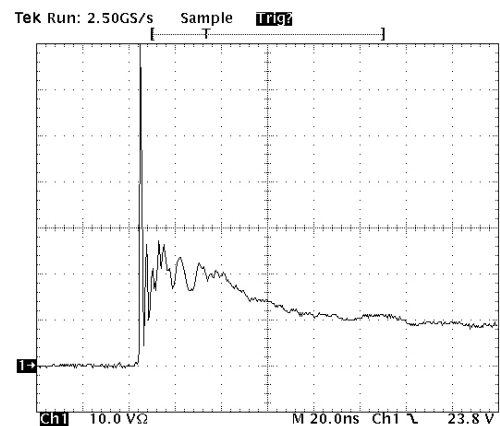

ESD Clamping Voltage

8 kV Contact per IEC61000-4-2

Typical Application

The ASRV05-4 is designed to protect four data lines from transient over-voltages by clamping them to fixed reference. When the voltage on the protected line exceeds the reference voltage (plus diode VF) the steering diodes are forward biased, conducting the transient current away from the sensitive circuitry. Data lines are connected at pins 1, 3, 4 and 6. The negative reference (REF1) is connected at pin 2. This pin should be connected directly to a ground plane on the board for best results. The path length is kept as short as possible to minimize parasitic inductance. The positive reference (REF2) is connected at pin 5.

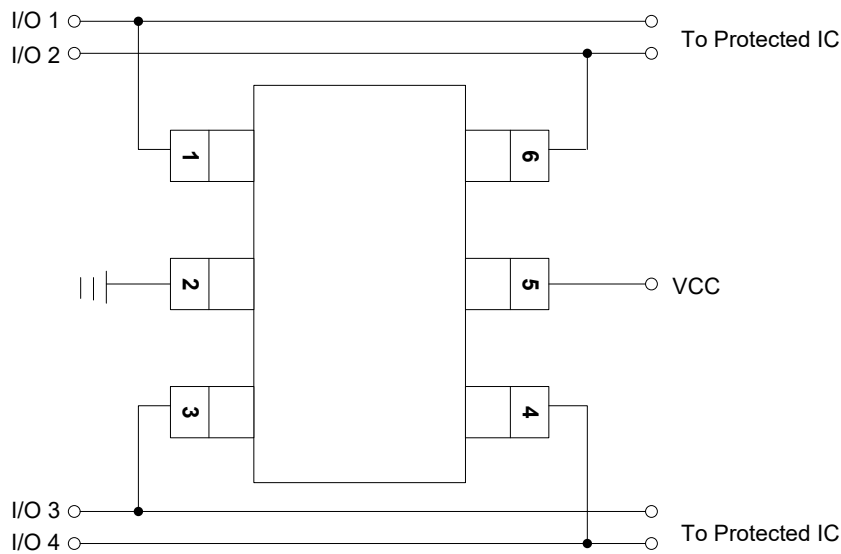

ASRV05-4 on Video Interface Application

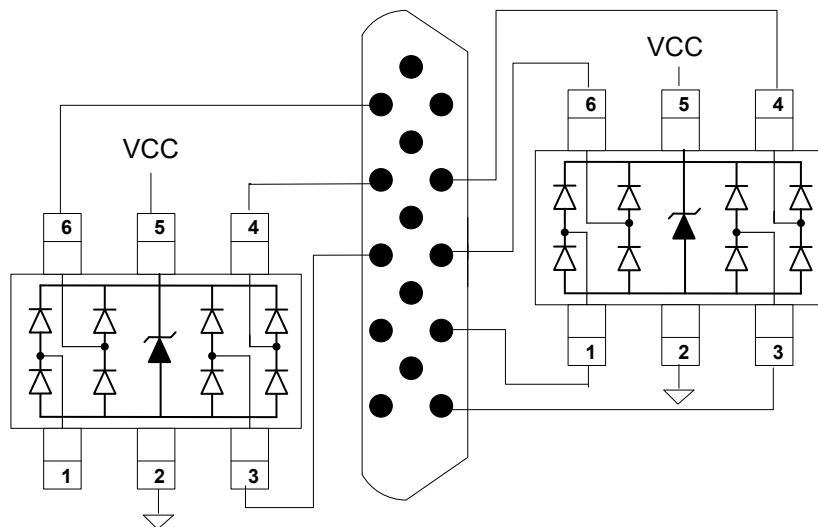

ASRV05-4 on USB Port Application

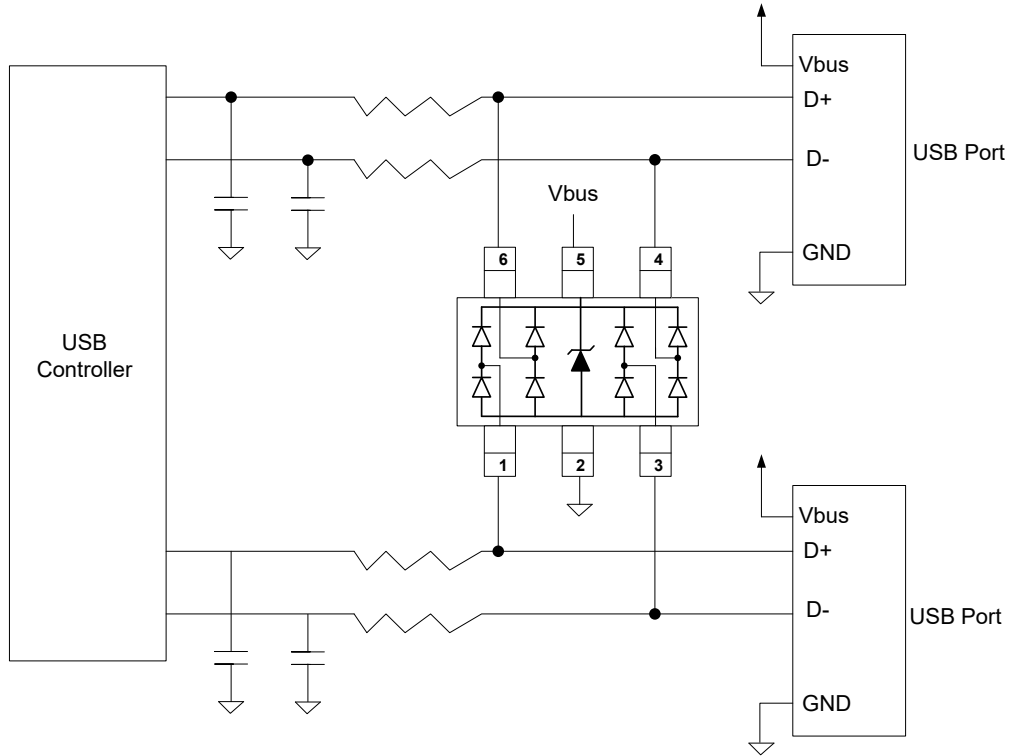

ASRV05-4 on SIM Port Application

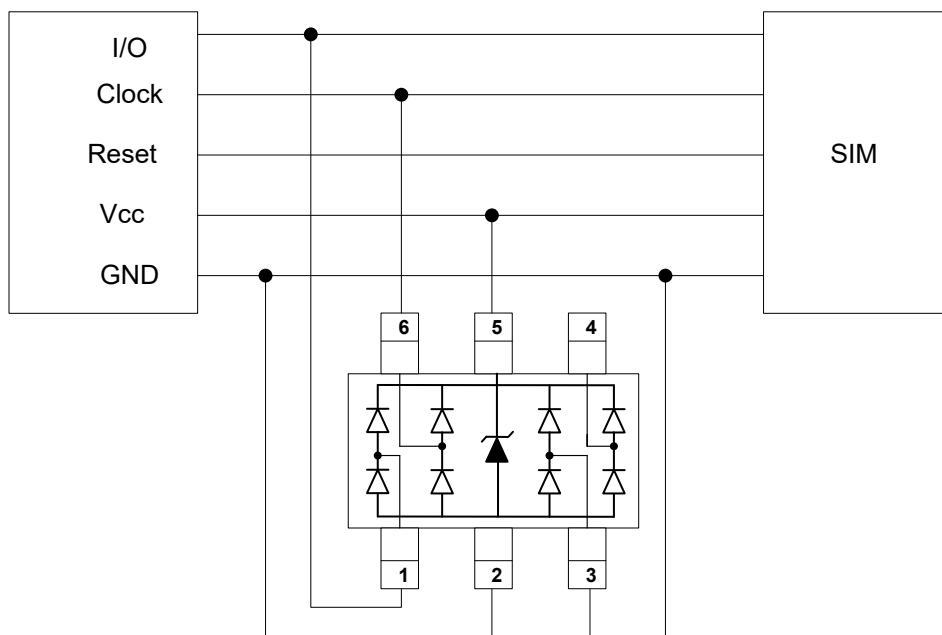

ASRV05-4 on Digital Visual Interface (DVI) Application

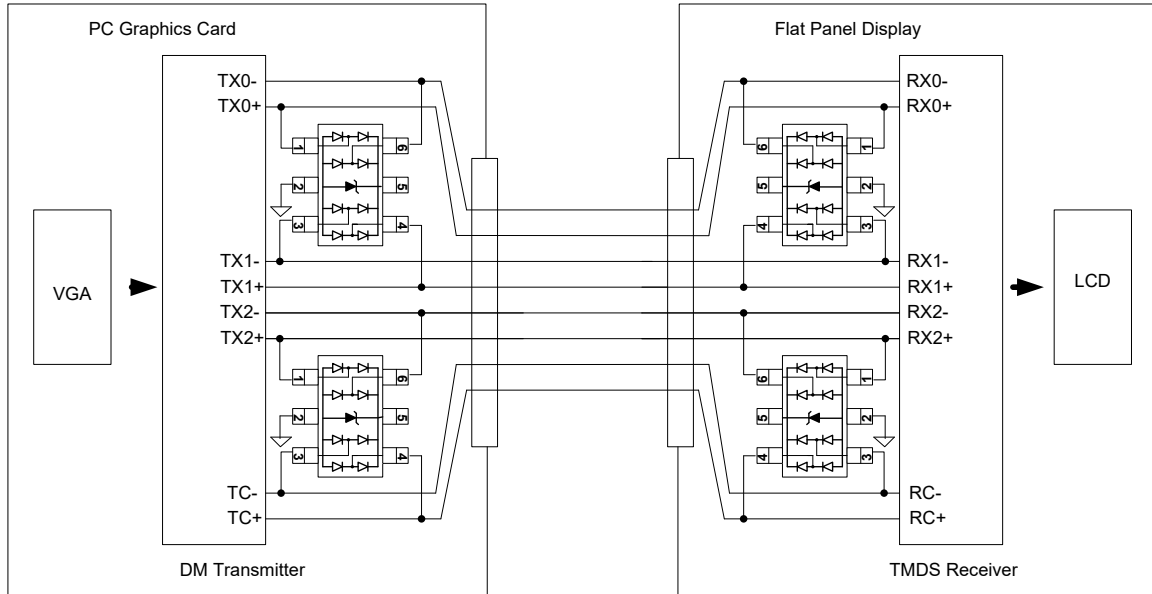

ASRV05-4 on Ethernet 10/100 (Differential mode) Application

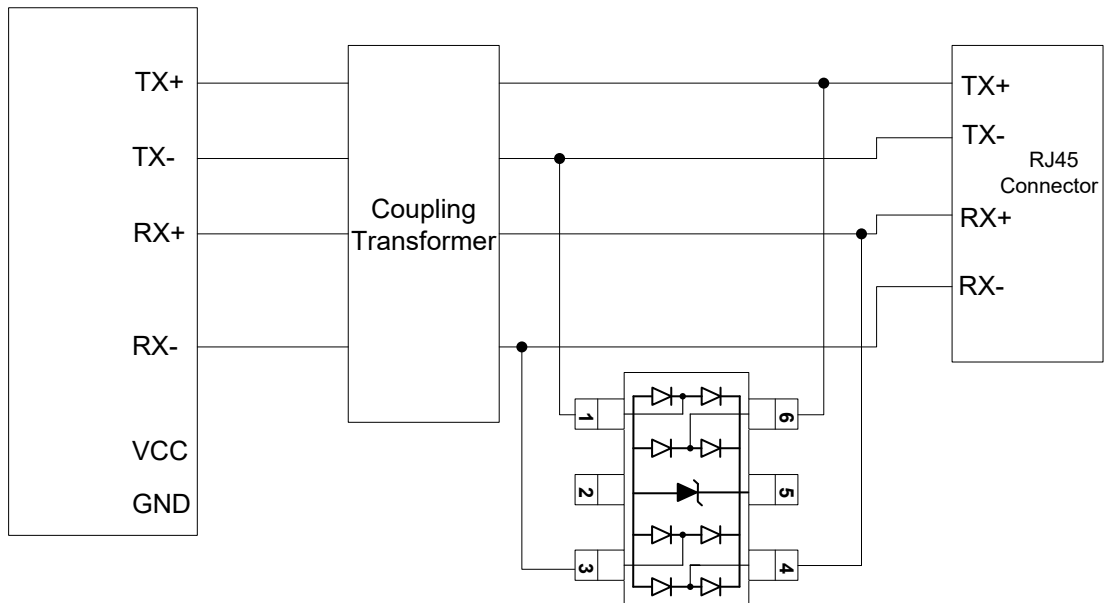

ASRV05-4 on T1/E1 Interface Application

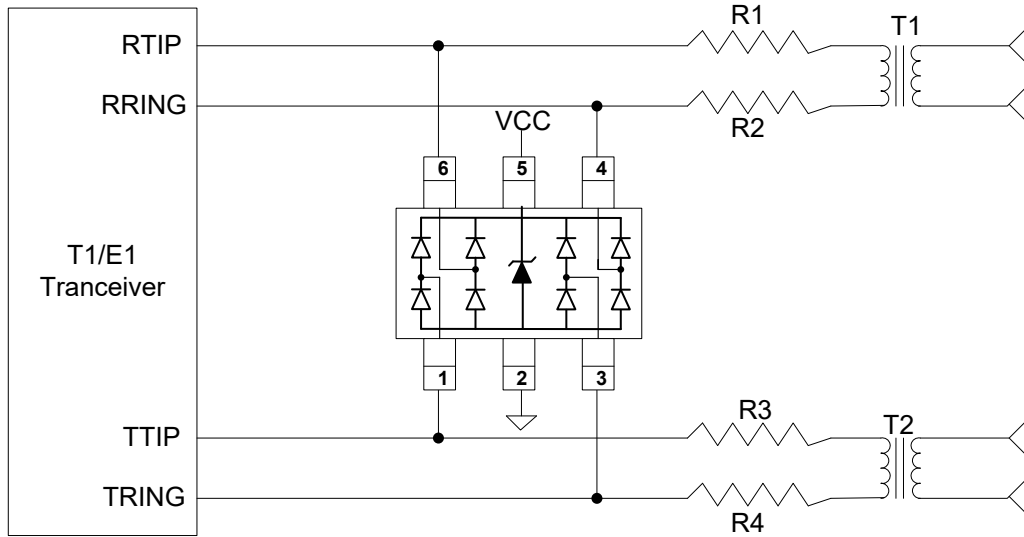

SOT23-6 Package Outline Drawing

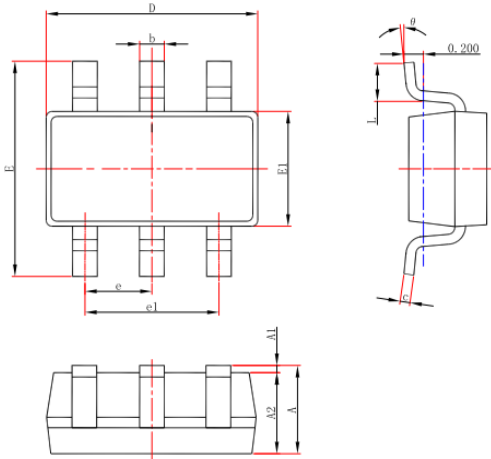

Symbol	Dimensions In Millimeters		Dimensions In Inches	
	Min.	Max.	Min.	Max.
A	1.050	1.250	0.041	0.049
A1	0.000	0.100	0.000	0.004
A2	1.050	1.150	0.041	0.045
b	0.300	0.500	0.012	0.020
c	0.100	0.200	0.004	0.008
D	2.820	3.020	0.111	0.119
E1	1.500	1.700	0.059	0.067
E	2.650	2.950	0.104	0.116
e	0.950(BSC)		0.037(BSC)	
e1	1.800	2.000	0.071	0.079
L	0.300	0.600	0.012	0.024
θ	0°	8°	0°	8°

Suggested Land Pattern

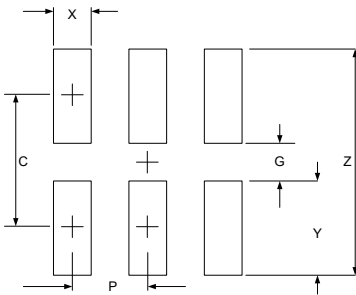

SYM	DIMENSIONS	
	MILLIMETERS	INCHES
C	2.50	0.098
G	1.40	0.055
P	0.95	0.037
X	0.60	0.024
Y	1.10	0.043
Z	3.60	0.141

Contact Information

Applied Power Microelectronics Inc.
 Room 5A11, Chuangjie Building, 178 South Yulong Road,
 Changzhou, Jiangsu 21300, P. R. China
 Phone: +86 (0519) 8375 8618, Fax: +86 (0519) 8375 6618